

INFORMATION ABOUT THE PRODUCT

Dimensions	40 x 340 cm
Safety zone	240 x 540 cm
Safety zone area	13 m ²
Overall height	114 cm
Free fall height	98 cm
Amount of users	2
Product complies with EN 1176-1:2017-12	YES
Availability of spare parts	YES
Age range	3-12
<small>According to EN 1176-1:2017-12 norm, the product requires applying a safety surface according to the product's free fall height.</small>	

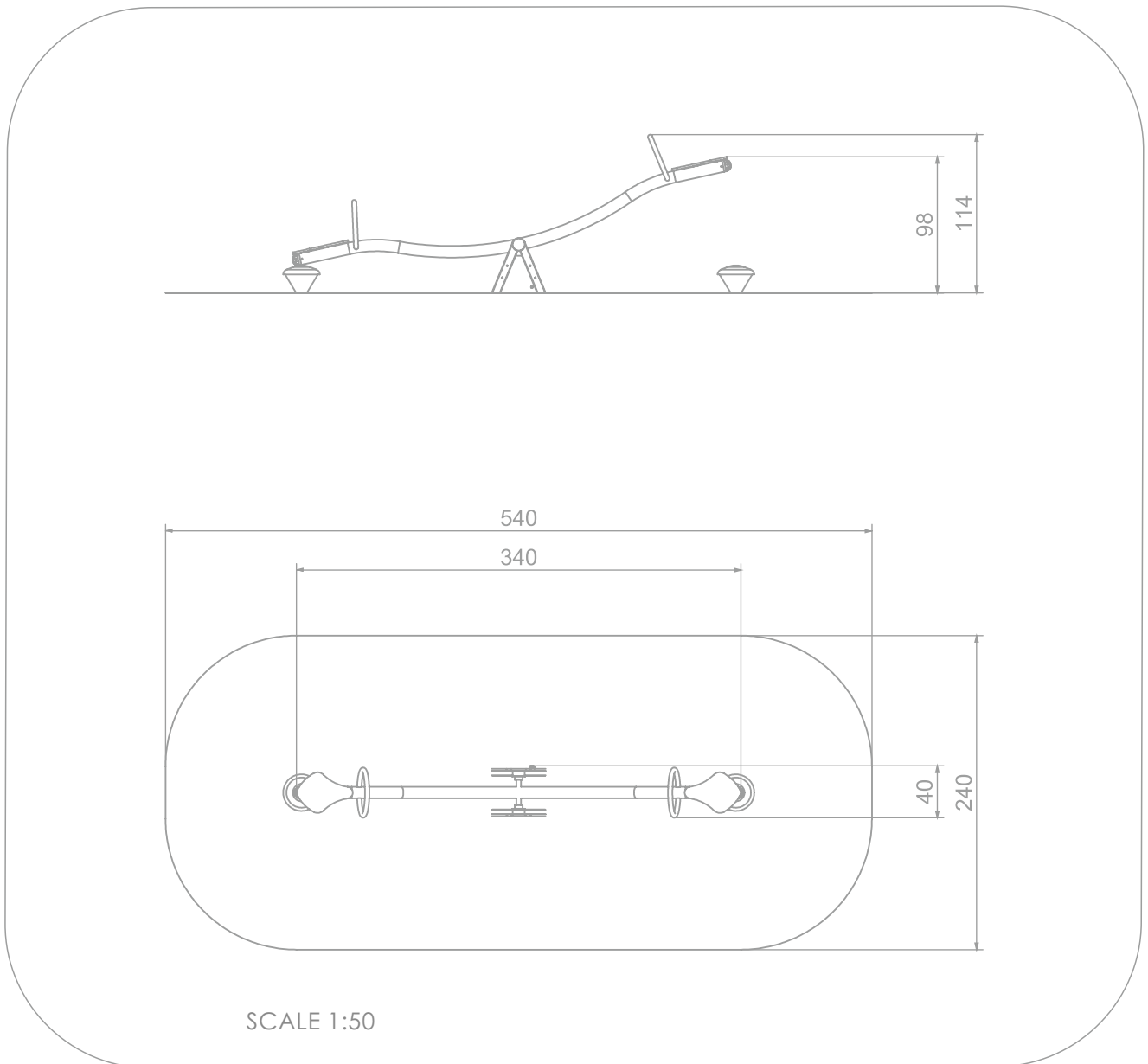



MATERIALS:

SOLID CONSTRUCTION
MADE OF STAINLESS STEEL
ASISI 304

PLATES OF THE WALLS MADE
OF COLORFUL TRIPLE
LAYERED 15 MM HDPE
POLYETHYLENE





AC 184

CERTIFICATE

No. 02/09/2019/01/00

Owner's certificate:

BUGLO Sp. z o.o.
ul. Zwycięstwa 276
75-653 Koszalin

Place of inspection:

ul. Zwycięstwa 282 B
75-653 Koszalin

Product name:

Swing symbol 4008



The product meets the requirements of:

PN-EN 1176-1:2017-12, PN-EN 1176-6+AC:2019-03

The type of certification program: 1b by PN-EN ISO/IEC 17067:2014-01

The certification program: CB-3/DCW

Certification contract No.: 02/09/2019/01

Certificate of compliance of the device with the requirements of the standards
as at 12 September 2019

The certificate applies only to the product presented for inspection.

Warsaw, 12th September 2019

Europejskie Centrum Jakości i Promocji Sp. z o.o.
Director of the Product Certification Department
Paweł Przesmycki